

PortaDot P50-25

Marking Window
50mm x 25mm

Weight
2.3kg

Versatile, lightweight handheld marking machine. Suitable for majority of applications.

Supplied with quick-change facemasks for marking on curved or flat surfaces. Also available with optional long-reach facemask and nosepiece.

Standard 4000 embedded controller provides full range of marking and control features. Optional battery powered version available.

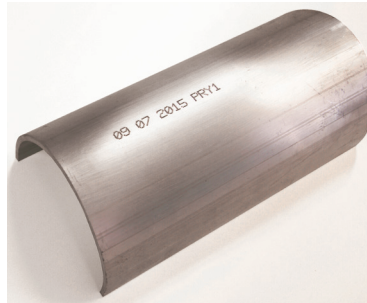

STANDARD FEATURES

- 4000 Embedded Controller
- Electromagnetic solenoid driven Dot Peen marking
- 90° stylus, 50mm long, 4mm diameter, carbide tip
- Supplied with 2 quickly interchangeable facemasks – for flat and curved parts
- Top mount handle to ensure marker can be held down firmly while marking

APPLICATIONS

- Immobile, large/heavy components
- Asset labelling
- Security marking
- Construction applications

OPTIONS

Description

Battery-powered controller	Controller is portable, does not require mains power
PC-based software control	Drag and drop editor, user admin rights, connectivity; PC required
Longer head cables	Marking at 6m or 10m from controller; reduced maximum marking force
Alternate nosepiece/stylus	Wider / shallower tip angle, IAQG spec, longer
Battery-powered controller	4000 controller with battery power, charger, spare battery and external mains supply

TECHNICAL DATA		● Standard ○ Optional
Marking area	50mm x 25mm	●
Weight	Head & Cable = 2.3kg; With controller = 7.3kg	●
Nosepiece & stylus	50mm long, 4mm diameter, 90° stylus tip, carbide Various alternatives available	● ○
Controller	4000 4000 Battery Controller	● ○
	100V or 240V mains supply 36V, xxAh rechargeable Li-Ion battery	● ○
Head cable length	3m 6m 10m	● ○ ○
Construction	Aluminium internals; tough plastic case	●
Operating temperature	0°C - 80°C (32°F - 176°F)	●
Supply requirements	240V 50Hz / 100v 60Hz	●
Workpiece hardness	Max. 62 HRC (800HV)	●
Marking type	5 x 7, 7 x 9, Varidot, logos,	●
Character sizes	0.15mm – 24.9mm in 0.15mm increments	●

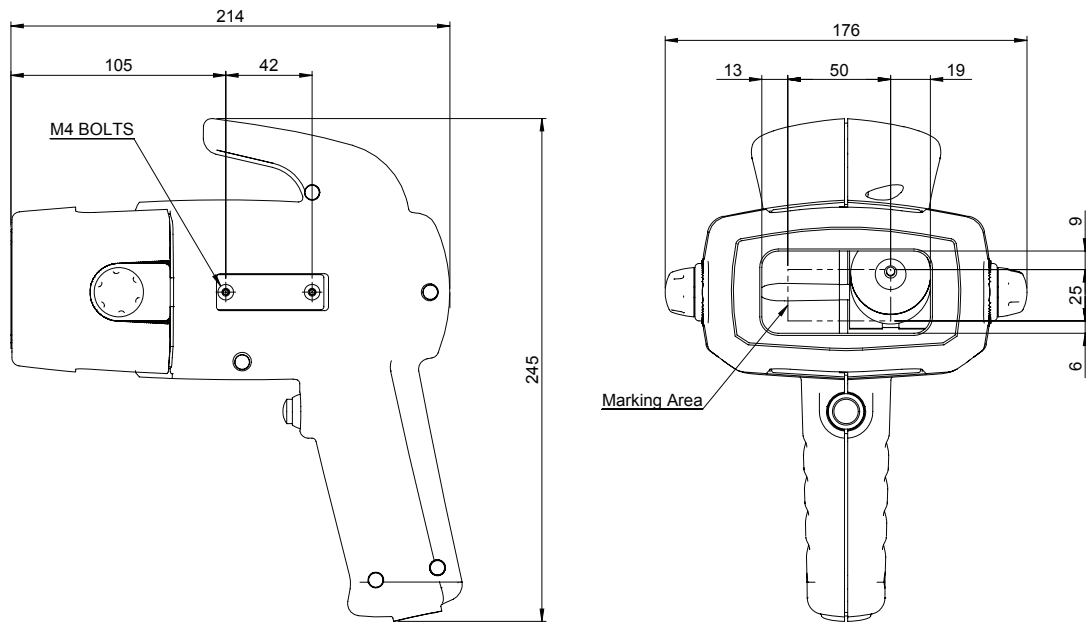

ACCESSORIES	Description
Extended Facemask	Facemask with 2 supports for accessing difficult locations / marking uneven surfaces. Supplied as kit with extended nosepiece and stylus.
Trolley	For holding and moving controller and marking head
Base and Column	For fixing P50-25 marker in place for bench-top marking
Balancer	For suspending
Spare battery	For optional battery version of 4000 controller
Barcode Reader	RS232 barcode scanner to select programme or input marking data
Custom Facemask	Custom-designed facemasks for marking specific components