

DMWRITER™ MX

DOT PEEN MECHANICAL CNC SPINDLE MARKING TOOL

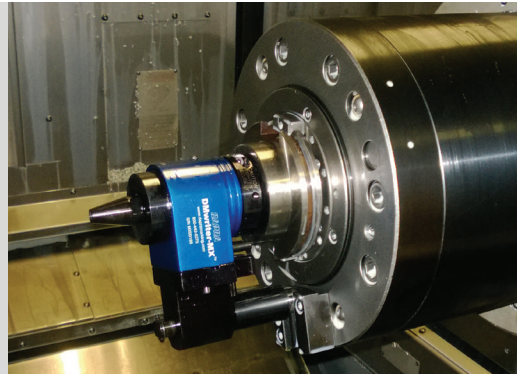

- An affordable alternative to secondary direct part marking – mark parts directly in CNC milling equipment
- No electric or pneumatic input required
- Use standard CNC engraving software
- Mark alphanumeric text, symbols and logos
- Use existing machine tool fixturing
- Most standard CNC shanks available
- Center distance available in 55mm, 65mm and 80mm – larger center distances available upon review of application

DMWRITER™ MX DIMENSIONS:

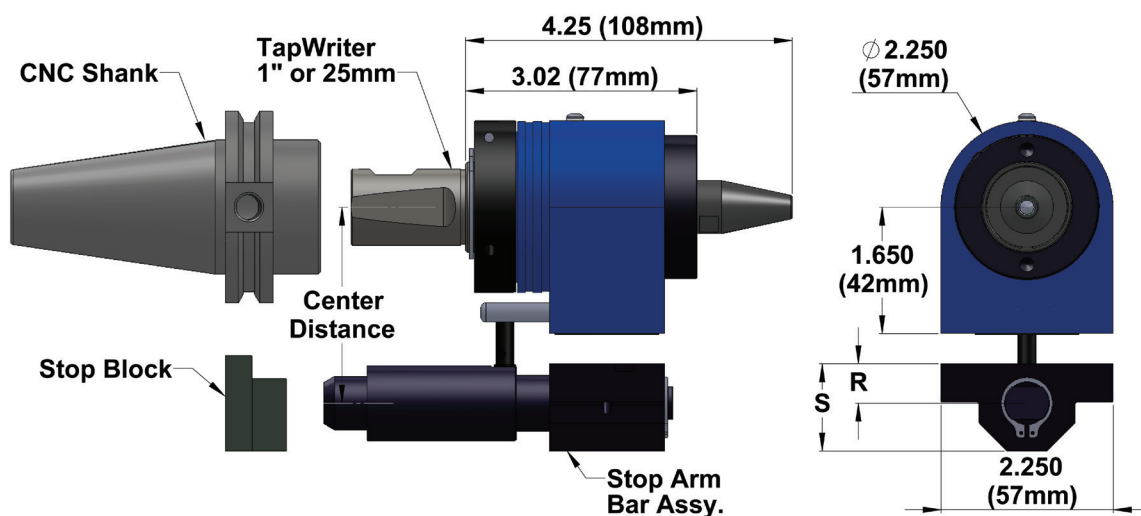

DAPRA
MARKING SYSTEMS

© 2016 Dapra Corporation - 201610

66 Granby Street, Bloomfield, CT 06002

860-286-8728 ♦ Fax: 860-242-3017 ♦ sales@dapramarking.com

800-442-6275 ♦ www.DapraMarking.com