

- Very fast
- Robust
- Deep marking
- Large marking window
- Electromagnetic (no air)

DAPRA[®]
MARKING SYSTEMS

Marktronic™ 3000 PortaDot™ 130-30E

Marktronic™ 3000 PortaDot™ 130-40E



PortaDot™: Portable Marking Machine

Marktronic™ PortaDot™ 130-30E

Marktronic™ PortaDot™ 130-40E

Portable and powerful dot marking machine capable of indenting components with deep marks. Robust mechanism and steel housing especially well suited to industrial applications. Electric Solenoid (no air connection) and large marking area

Applications Include:

- 2D Data Matrix marking • Component traceability • Steel stock marking • Serial numbering
- Chassis VIN marking • Time and Date marking • Cast and forge marking • Part numbering
- Batch and Shift coding • Programmable marking • Component identification

intelligent marking solutions

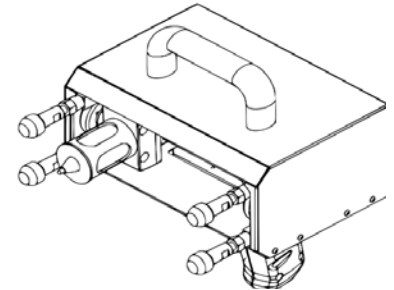
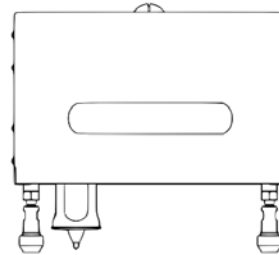
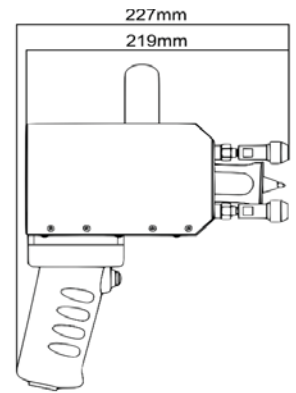
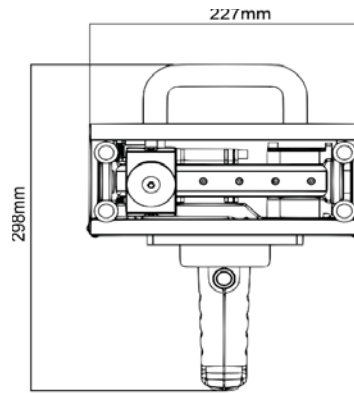

Technical Specifications

(For more technical details please see our website)

	130-30	130-40
Marking Area:	130mm x 30mm	130mm x 40mm
Stylus Length:	50mm	100mm
Character Sizes:	0.30mm - 99.9mm in increments of 0.30mm	
Marking Formed:	5 x 7, 7 x 9, Varidot, OCR fonts	
Memory Capacity:	3000 Controller: 1350 Layouts, PC: Unlimited	
Weight:	Marking Head: 5kg Controller: 10kg	
Electrical Supply:	220 50Hz, 110v 60Hz	

Robust and Fast

- Professional design for industrial applications
- Robust components in steel housing
- Very fast and accurate
- High torque motors and precision lead screw

Powerful Electromagnetic Dot Marking

- No air, just one standard electrical supply
- Deep permanent marks
- High consistency of marking depth
- Fully controlled number of dots per character and dot location
- Mark most engineering materials, plastic to 62HRc steel
- Quieter than pneumatically operated machines

Excellent Marking Quality

- Highest marking legibility of numbers and letters
- Company logo marking with high precision
- Excellent Data Matrix marks, improves reading rate

Highly Flexible

- Large marking area of 130x30mm or 130x40mm
- 3 metre cord
- Convert to bench-top machine with base and column option

Easy To Use Out Of The Box

- User friendly software reducing operator training
- Software preloaded in controller

Controller and Interface

- 3000 series controller with membrane keyboard, screen and software
- No need for a separate PC
- Very large and high contrast screen allowing preview
- 2 x RS232, Ethernet TCP/IP (optional) and digital I/O ports
- Windows[®] PC based software available

Marking Software Features

Among extensive features available as standard:

- Straight, angular and arc marking, Data Matrix codes
- Logo marking - PLT files
- Serial numbers, date and time marking
- Choice of character definition and size marking force

Options

- Column and base
- 6 metre cable
- Barcode reader
- TCP/IP Ethernet network port
- Electromagnetic clamping
- Customized part locating or clamping

