

DMwriter MX All-in One Overview

Advantages, Function and Characteristics of the DMwriter MX.

The DMwriter MX Marking Head was designed as an easy to use, economical, spindle actuated permanent marking device for a wide variety of materials from hardened tool steel to delicate plastics. Since the device does not rely on electrical or compressed air input or any similar interfacing, it is easily integrated into vertical or horizontal machining centers, milling machines and equivalent CNC machines with rotating spindle. The process is similar to integrating a tapping head or angle head into a milling machine.

The DMwriter MX can be manually mounted in the machine spindle, or it may be placed in the machine's ATC (automatic tool changer) and automatically loaded into the spindle. The DMwriter MX is a very cost-effective, smart alternative to costly dot-peen marking machines, vibrating stylus heads, pin marking machines, or alternative marking methods including chemical etching, die or roll stamping, laser markers and messy ink printers. The machining envelope of the machine tool the DMwriter MX is used on, is the only limit of the size and area to be marked. The "marking window" is therefore far larger than on virtually any dot-peen or other marking machine available. Parts that are machined on a machining center can be marked in location and do not have to be moved, located and re-fixtured on a separate marking machine, saving costly handling and processing time and preventing errors. Multiple parts on a tombstone or index fixture, or in gang fixtures or multiple vises can be marked in location in one marking cycle.

The DMwriter MX has a number of important advantages and characteristics over other conventional marking methods. The DMwriter MX is a spindle-actuated mechanical Dot-Peen Marker, which cold-forms a series of discrete or connected dots with precise, low stress marking force. The device accurately and indelibly marks alpha-numeric text, symbols, dates and serial numbers, batch codes, logos and graphics. Various fonts and character sizes can be marked in straight-line, angled, arced, circular, mirrored or reflected text. The carbide stylus can easily mark in a wide variety of materials: it clearly marks cast iron or steel as hard as 55 HRc or dense material like heavy metal, but just as easily marks softer materials like aerospace alloys, aluminum, other non-ferrous metals, and delicate plastics.

DMwriter MX integration is also simple. Most general purpose Machining Centers or Milling Machines now are equipped with CNC controls with engraving software; this makes the use of the DMwriter MX Marking Head very straightforward. Older machines, which have no engraving feature, can be equipped with commercially available, low-cost engraving software, or a PC-generated marking program may be downloaded for execution by the machine control. Marking capabilities of the DMwriter MX head depend only on the capabilities of the machine's engraving or CAD software used. The dot-peen marks produced by the DMwriter MX head are an easily readable and permanent for product identification or traceability requirements. The DMwriter MX head provides a very affordable and cost-effective solution for permanent parts identification in a wide range of manufacturing industries.

The DMwriter MX functions by actuating a tungsten carbide stylus with controlled radius tip. The top of the stylus is struck by the actuating hammer and "thrown" inside a nose cone downward with velocity toward the marking surface. Near the end of the stroke movement, the stylus tip penetrates the surface to be marked. The tip of the stylus creates a controlled indentation ("Dot"). A stylus return spring under the stylus cap returns the stylus back up to the starting position. The depth of the indentation depends on the velocity of the stylus and on the resistance (hardness and density) of the work-piece material to be marked. Slight work piece surface height variations do not change the marking depth, an important feature when marking castings, forgings, curved surfaces or the like. Changing the rotational speed of the machine spindle can vary the marking depth. Slower rotational speed will decrease the velocity of the marking stylus and result in less marking depth, increasing the rotational speed will generally result in a deeper mark. Varying the marking plane distance from the marking surface can also have some effect on the penetration of the stylus but to a lesser degree than changes in the rotational speed.

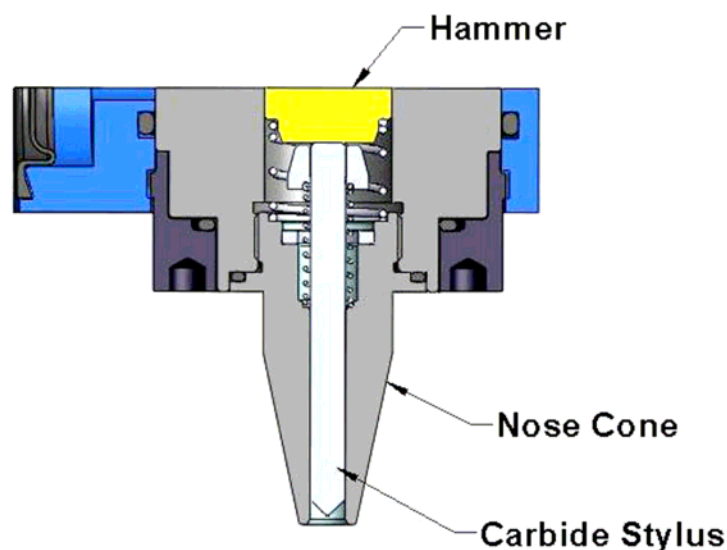

Set-up Guide:

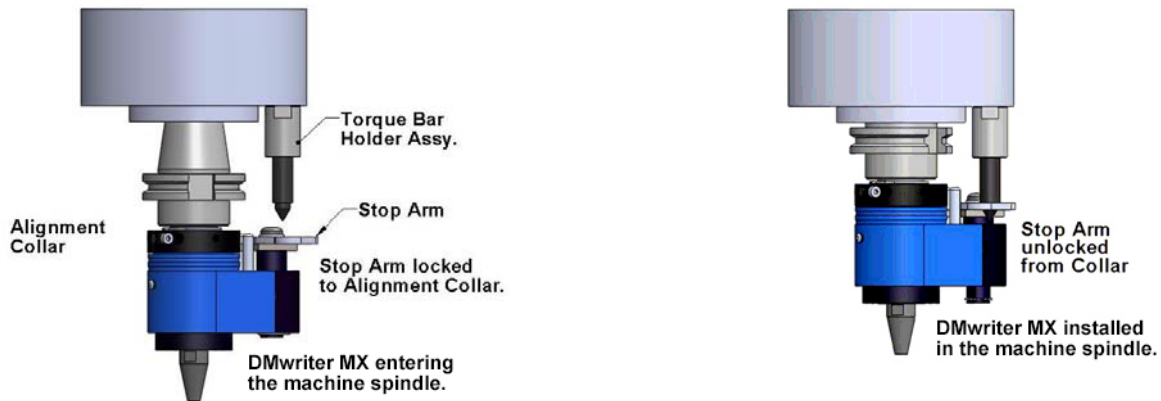

In order for the DMwriter MX to operate, a stop arm is used to prevent the housing from rotating. To allow the tool to travel through an automatic tool change and the stop arm to find the stop location next to your machine spindle, the alignment collar locks the stop arm in a specific orientation. This alignment collar can be adjusted so that its slot is in any position relative to the NC shank. When the tool is out of the machine spindle, the stop arm is engaged in the slot in the alignment collar. This then keeps the stop arm locked in its orientation position. When the tool is placed in the machine spindle by the tool changer, the stop location next to the machine spindle engages the stop arm preventing it from turning and at the same time pushes it down against a spring so that the stop arm is unlocked from the alignment collar. This is the position for operation. When the marking operation is completed the machine spindle orients to the tool change position bringing the slot in the alignment collar back in to position to accept the stop arm as the tool is removed from the machine spindle by the tool changer



Do not attempt to make an automatic tool change until all steps are completed and clearance has been confirmed.

Never attempt an installation with out first reading all safety instructions for this tool and your machine.

Automatic tool changes should only be made on enclosed machines.

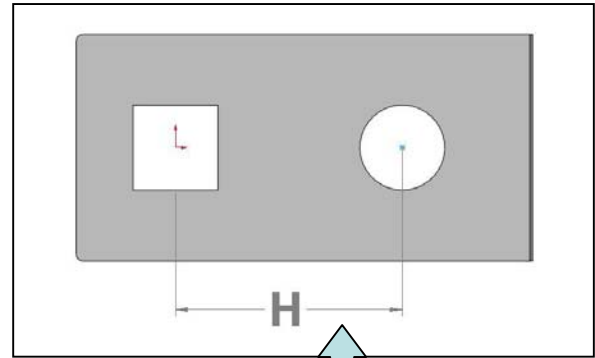
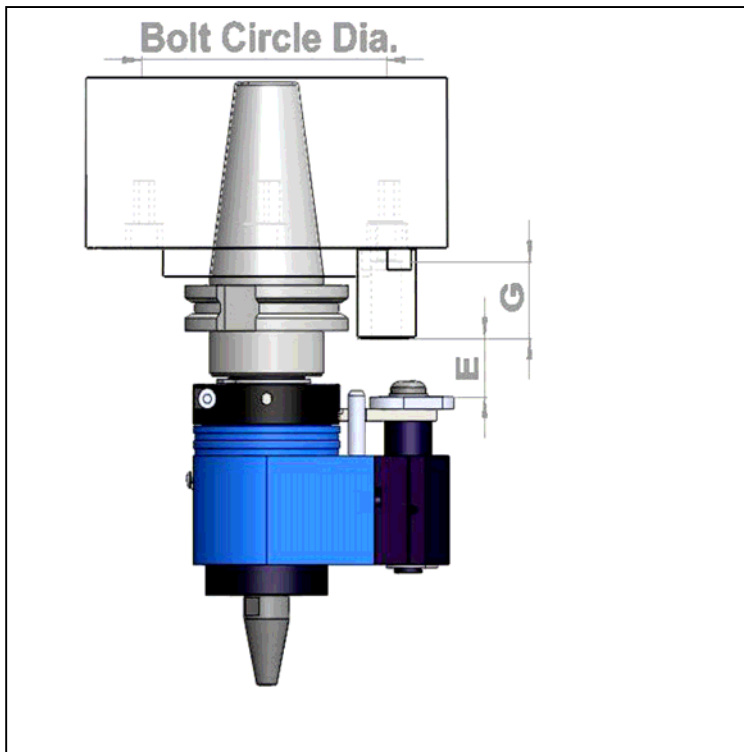

**STOP ARM
TORQUE BAR**

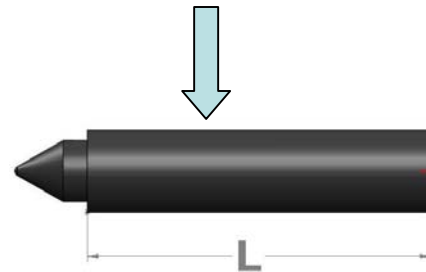

$$L = G + E + 10\text{mm}$$

Modifying or selecting the Stop Arm: The DMwriter MX comes with a blank stop arm that can be modified to fit the bolt circle of your machine. First determine the bolt circle diameter shown in the figure above. If you would like to order a ready made stop arm please let us know the bolt circle diameter and we can supply the stop arm to fit your machine. If you would like to modify the blank stop arm enclosed you will need to drill a 10mm hole at “H” as given by the following formula.
 $H = (\text{Bolt Circle Diameter}/2) - 55\text{mm}$

Cutting Torque Bar to Length: Please let us know the size of the thread of the bolt you wish to use for mounting the anti-rotation bar and we can supply a ready-made bar for your machine. The length for the bar is indicated by the formula shown above. The torque bar must be long enough to push the stop arm down to unlock from the alignment collar but not so long that it bottoms out against the top of the housing.

Important: Be sure to adjust alignment collar according to the instructions.

Alternative STOP BLOCK Installation

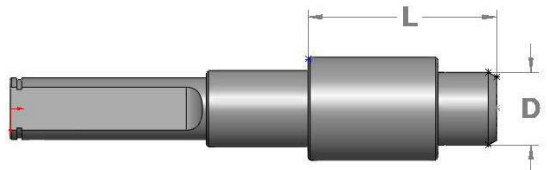
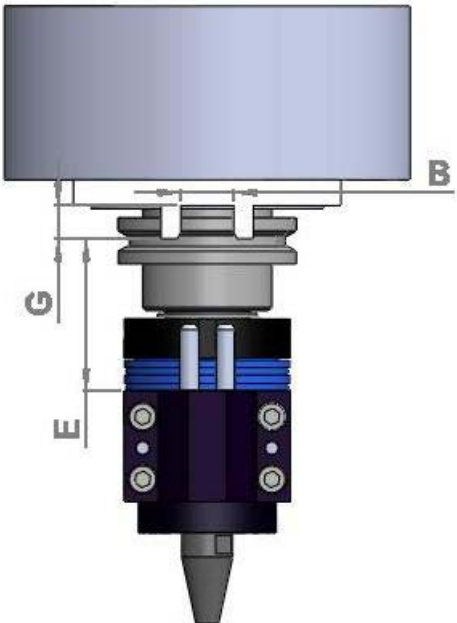
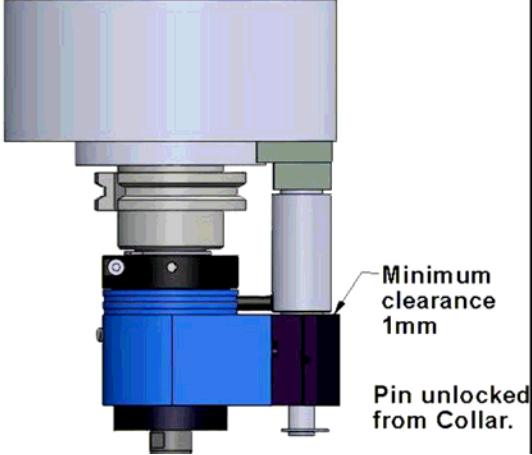
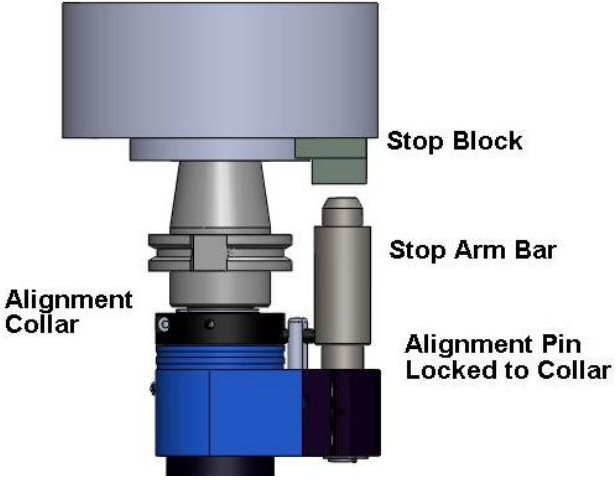

STOP ARM BAR
 $L = E + G - 1mm$
 $D = B - 0.4mm$

Please let us know whether the distance from the centerline of your machine is 55mm, 65mm, or 80mm and we can supply the correct assembly for your machine.

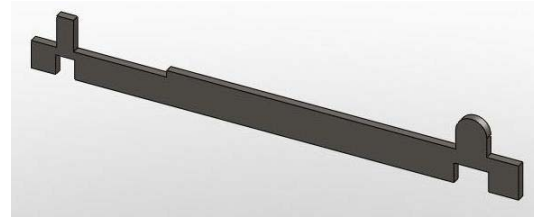
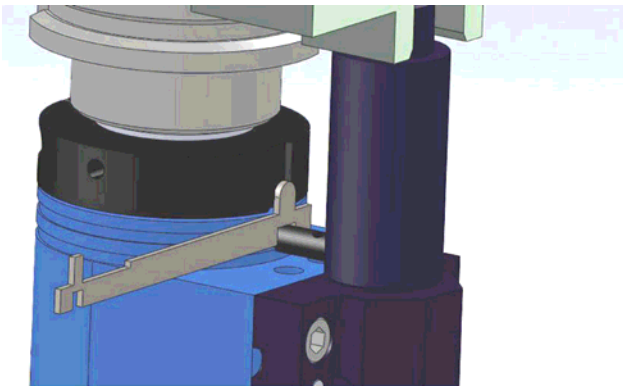

Alignment Key

Adjustment of the Alignment Collar: With the DMwriter MX in the machine spindle and the stop arm engaged with the stop location next to your machine spindle, **orient the machine spindle to the tool change position**. Bring the slot in the alignment collar in line with the tab of the stop arm. There is a small alignment key included with the tool to help you to line this up. **Tighten the collar's clamping bolt very securely.**

With the collar set and after checking for any possible clearance problems with the tool changer or in the storage area, make several automatic tool changes.

Set-up on work piece and Programming

Clearance Plane, Marking Plane, RPM, feed rate (X & Y-Axis) and down feed (Z-axis).

With the tool loaded in the machine spindle and the spindle rotating, the conical tip of the marking stylus protrudes slightly below the lower end of the nose cone when the stylus is fully extended at each marking stroke. Therefore the tool needs to be programmed / positioned so there is clearance between the lower end of the nosepiece guide and the flat marking surface; this clearance is known as the **Marking Plane** clearance. After marking each character or line, the tool needs to lift off the marking surface, so no dots are marked as the machine moves the tool in X- or Y-axis direction to the start of the next letter or line to be marked. The plane the tool is programmed to lift off to is known as the **Clearance Plane**. The lift off in Z-axis must be programmed to be fast, either in rapid mode or at a very fast feed rate. Likewise the down movement in the Z-axis should be made at the same fast speed. This is very important in order to avoid double hits of the stylus at the start and end of a character or line; it also reduces marking time substantially. Up to 75% time reduction over standard engraving with solid engraving tools has been reported.

