

 **TECHNO***mark*<sup>®</sup>

CREATIVE TRACEABILITY



**MULTI***4*<sup>®</sup>  
DOT PEEN & SCRIBING

# TECHNOMARK: EXPERIENCED PROVIDER OF INDUSTRIAL MARKING AND TRACEABILITY SOLUTIONS



For 10 years, TECHNOMARK has been a leader in the permanent, direct part marking industry. Based on our success of the Multi4 modular concept, we are introducing the latest generation of direct part marking solutions, the Multi4, Version 3 !

## A SURE KNOW-HOW:

Technomark's core, permanent marking developments have evolved at a rapid pace over the last several years. Starting as a manufacturer of standard marking machines, we are currently offering global solutions for direct part marking and traceability.

TECHNOMARK bases its expertise around three core strengths:

- Permanent marking using the technology of electromagnetic dot peen and pneumatically actuated scribing.
- Reading and verifying of DataMatrix codes and other 2D symbologies.
- Custom engineered and turn key solutions for special marking requirements involving direct part marking, reading/verifying, database management and part handling...

TECHNOMARK'S diverse expertise is found in many industrial sectors:

- Aerospace
- Automotive
- Defense
- Medical
- Nuclear
- Metal work

## ONGOING INNOVATIONS:

TECHNOMARK invents the 4 in 1 concept when introducing the MULTI4\*, the very first marking equipment fully modular.

1 unique machine = 4 possible configurations

Patent # FR9914782

TECHNOMARK introduces intelligent direct part marking: IDI ensures the level of quality and consistency of the marking data.

International patent pending N°PCT/FR2006/001246



## EXPERIENCED IN MARKING TECHNOLOGIES

TECHNOMARK offers two Direct Part Marking technologies :

### ELECTRO-MAGNET DOT PEEN

The concept is to create characters, symbols and codes by cold forming dots directly into the work piece material through an oscillating stylus. This method creates a permanent, low stress mark on most materials under 65 Rc.



### PNEUMATIC SCRIBING

The principle is based on penetrating a stylus into the material by pneumatic pressure and creating highly visible, continuous line characters. The scribing process is quiet, less than 72 dB(A), and ideal for marking applications where excessive noise may be an issue, for tooling of high hardness and also aesthetical marking.



## A LONG LASTING PARTNERSHIP

TECHNOMARK is committed to long term support with all of its customers and partners. This commitment is based on 3 factors:

- **Total Support:** understanding you requirements, overall maintenance of your Multi4 and financial solutions
- **Implementation:** custom engineered and modified solutions for specific applications
- **Follow up:** product training and efficient maintenance of installed Multi4 systems.

## QUALITY MARKING AND ENVIRONMENTAL FRIENDLY

Currently, TECHNOMARK is the only company in France to have obtained both of the following certifications: ISO 9001 Version 2008 and Investor in People.



Emphasis of Certification:

- **its knowledge base** and quality management
- **its interpersonal skills** and the quality of its management



INVESTOR IN PEOPLE

From the beginning, TECHNOMARK has been environmentally conscious of problems associated with industrial products.

As a result, TECHNOMARK has implemented a set of actions aimed at reducing the negative impact on the environment by using recycled materials and optimizing the Multi4 power consumption.





MULTI4  
NEW GENERATION!

# MULTI4<sup>®</sup>

## 1 PRODUCT 4 CONFIGURATIONS

### MULTI4 BENEFITS

- **Easier to use:** simplified user interface, intuitive navigation, new and improved features (zooming, cutting/pasting, test...)
- **Better resolution:** high definition color screen
- **More intuitive:** icon based navigation menu allows for quick understanding and operation of the software
- **Improved ergonomics:** new design with a second handle (optional accessory)
- **Improved handling:** support foot, controller handgrip and handle on the marking head (optional)
- **Reduced weight:** marking head weight reduced by around 0.88 lbs
- **More robust:** use of cast aluminum parts
- **Enhanced performance:** increase of the marking speed by 20% and optimization of the overall X/Y movement, standard management of 3 axes
- **More resourceful:** 40Mb of memory can accommodate up to 20,000 stored, marking files (40 characters, 1 line), serial communication, USB, Ethernet (option) and Inputs/Outputs



PREMIUM





## MULTI 4<sup>®</sup> Bench

For very small, small to medium sized parts

## MULTI 4<sup>®</sup> Hand-Held

Ideal for large and cumbersome parts

## MULTI 4<sup>®</sup> Combo

Offers maximum flexibility for marking small and large parts

## MULTI 4<sup>®</sup> Integrated

Compact, good fit for automated integration

## TECHNICAL ATTRIBUTES :

### IDI marking:

The quality of marking is ensured, whatever the difference in height between the part (flat or cylindrical) and the stylus. Its adjustment is managed by the Multi4 software.

### IDI control:

Real-time Multi4 monitoring for analysis of maintenance needs, stylus wear and detection faults (auto-diagnosis feature with 5 control points).

(1) Marking with IDI Premium

(2) Marking without IDI Premium

## ECO-DESIGN

- 80% of the used materials can be recycled
- Two programmable modes for reducing power consumption between 40% and 98%!
- Reduction of the carbon footprint by using local suppliers and limiting transportation requirements
- Dry marking (no material removal, no waste, no fumes)
- No consummables
- Reduction of mechanical parts wear



Displayed model: Multi4 200

# MULTI 4<sup>®</sup> Bench

## For very small to medium sized parts

### PRECISE

Multiple fixturing options for optimal positioning of the marking head.

### SMART

Fast vertical height adjustment with "Quick Shift" feature (see technical features).

### SIMPLE

Ergonomics of the Multi4 Bench optimized for marking many different part configurations.

### EFFICIENT

Easy to start marking, from a single part to mass production.

## REAL APPLICATIONS

- (1) Marking of a nameplate
- (2) Marking of a serial number on a metal part





## TECHNICAL FEATURES (MULTI4 200)

- Marking window: 7.87" x 2.36"
- Carbide tungsten stylus with 90 degrees included angle (available in 60 and 120 degrees)
- Quick Shift feature: Clutch release of the locking mechanism for fast vertical moving and precise positioning of the marking head to the part

|        | Head     | Bench/column |
|--------|----------|--------------|
| L      | 11.61"   | 16.22"       |
| I      | 5.67"    | 12.20"       |
| H      | 8.90"    | 25.83"       |
| Weight | 8.16 lbs | 39.68 lbs    |

*Dimensions given in inches (excluding upper handle) and weight given excluding the cable*

## POWER AND ENVIRONMENT

- Power : 250 W
- Frequency : 50 to 60 Hz
- Input power : 90 to 240 VAC
- Operating temperature: 32 to 115°F

## MARKING HEAD MODELS

- Head 50 (1.97" x 2.36")
- Head 120 (4.72" x 2.36")
- Head 200 (7.87" x 2.36")
- Head 200 XL (7.87" x 7.87")

## STANDARDS

- 2006/42/CE «machines» directive
- 2004/108/CE «CEM» directive
- 2006/95/CE «low voltage» directive
- FCC Chapter 15 directive

## MULTI4 CONTROL UNIT



- High resolution (640x480 px) color screen with icon based navigation



- Intelligent handling of the marking 
- RS232 connection, 3 Inputs / Outputs, Ethernet (optional)
- 2 USB: Device Port & HOST
- One further optional axis available (total of 4 axes)
- Embedded Multi4 software in 21 different languages
- Memory capacity of 40Mb of memory can accommodate up to 20.000 stored, marking files (40 characters, 1 line)
- Well designed ergonomics (locating foot and carriage handle)
- Fast updates in less than 2 minutes through USB port
- Various marking modes: Text, variable data, serial number, data codes, logos and 2D codes
- Straight, angular, circular and radial marking
- « Easy Shift » feature: allows to display text moving in the marking window.
- (L x W x H) : 14.57" x 8.46" x 5.47"
- 8.16 lbs (including power cord)

## MAIN ACCESSORIES AND OPTIONS

- |                                       |                                |                            |
|---------------------------------------|--------------------------------|----------------------------|
| 01 - Plates support                   | 06 - Extended column (+ 3.94") | 11 - Maintenance kit       |
| 02 - Parts support                    | 07 - Autosens                  | 12 - Software pack         |
| 03 - Automatic nameplate \ tag feeder | 08 - Extended bench            | 13 - Cycle start footpedal |
| 04 - Ethernet port                    | 09 - Standard Rotary D axis    | 14 - Start/Stop box        |
| 05 - Electric Up/Down Z axis          | 10 - Heavy Duty Rotary D axis  |                            |



Displayed model: Multi4 50

# MULTI 4<sup>®</sup>

Hand-Held

## Ideal for large and cumbersome parts

### AUTONOMOUS

With (optional) battery kit, it can be used in locations where an electric source is unavailable.

### STRONG

Its cast aluminium frame makes it more robust and stronger while diminishing maintenance needs.

### EASY TO USE

Its specially designed locator allows for excellent support while marking.

### HANDY

An additional handle is mounted to the marking head for increased stability, regardless of head position.

## APPLICATIONS AND REALISATIONS

(1) Marking of a cylindrical part in bronze

(2) Multi lines radial marking





**MULTI4**<sup>®</sup>  
Hand-Held

## TECHNICAL FEATURES (MULTI4 50)

- Marking window: 1.97" x 2.36" mm
- Carbide tungsten stylus with 90 degrees included angle (available in 60 and 120 degrees)

|        | Head     |
|--------|----------|
| L      | 5.71"    |
| I      | 10.47"   |
| H      | 8.90"    |
| Weight | 9.26 lbs |

*Dimensions given in inches including gun kit (excluding upper handle) and weight given excluding the cable*

## POWER AND ENVIRONMENT

- Power : 250 W
- Frequency : 50 to 60 Hz
- Input power : 90 to 240 VAC
- Operating temperature: 32 to 115°F

## MARKING HEAD MODELS

- Head 50 (1.97" x 2.36")
- Head 120 (4.72" x 2.36")
- Head 200 (7.87" x 2.36")

## STANDARDS

- 2006/42/CE «machines» directive
- 2004/108/CE «CEM» directive
- 2006/95/CE «low voltage» directive
- FCC Chapter 15 directive

## MULTI4 CONTROL UNIT



- High resolution (640x480) color screen with icon based navigation



- Intelligent handling of the marking 
- RS232 connection, 3 Inputs / Outputs
- 2 USB : Device Port & HOST
- Optional battery kit for use when electrical power is not available
- Embedded Multi4 software in 21 different languages
- Memory capacity of 40Mb of memory can accommodate up to 20.000 stored, marking files (40 characters, 1 line)
- Well designed ergonomics (locating foot and carriage handle)
- Fast updates in less than 2 minutes through USB port
- Various marking modes: Text, variable data, serial number, data codes, logos and 2D codes
- Straight, angular, circular and radial marking
- « Easy Shift » feature: allows to display text moving in the marking window
- (L x W x H) : 14.57" x 8.46" x 5.47"
- 8.16 lbs (including power cord)  
10.80 lbs (including optional battery)

## MAIN ACCESSORIES AND OPTIONS

- |                      |                                |                        |
|----------------------|--------------------------------|------------------------|
| 01 - Battery kit     | 05 - Additional holding handle | 09 - Protective cover  |
| 02 - Bench kit       | 06 - Bar End Tool              | 10 - Transport trolley |
| 03 - Maintenance kit | 07 - Suspension hook           |                        |
| 04 - Software pack   | 08 - 5 and 10 m cable          |                        |



Displayed model: Multi4 120

# MULTI4<sup>®</sup> Combo

## Fits with all kind of parts and needs

### DIVERSE

From small components to parts weighing several tons.

### INTUITIVE

With its user friendly software, the Multi4 Combo is very simple to use.

### FLEXIBLE

In less than 10 seconds, without tools, the Bench version can be converted into a Hand-held.

### VALUE FOR MONEY

Based on its flexibility, you receive two configurations in a single marking system.

## APPLICATIONS

- (1) Serial number with a logo
- (2) Datamatrix marking



1

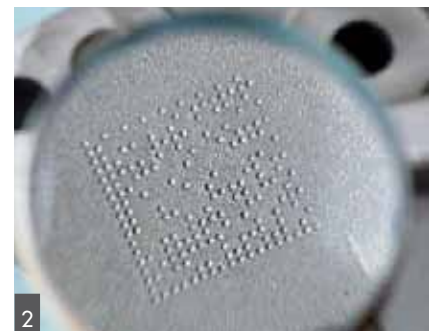

2

## MULTI4<sup>®</sup> Combo

### TECHNICAL FEATURES (MULTI4 120)

- Marking window: 4.72" x 2.36"
- Carbide tungsten stylus with 90 degrees included angle (available in 60 and 120 degrees)
- Quick Shift feature: Clutch release of the locking mechanism for fast vertical moving and precise positioning of the marking head to the part

|        | Head     | Bench/column |
|--------|----------|--------------|
| L      | 8.46"    | 16.22"       |
| I      | 10.47"   | 12.20"       |
| H      | 8.90"    | 25.83"       |
| Weight | 8.38 lbs | 39.68 lbs    |

*Dimensions given in inches (excluding upper handle) and weight given excluding the cable*

### POWER AND ENVIRONMENT

- Power : 250 W
- Frequency : 50 to 60 Hz
- Input power : 90 to 240 VAC
- Operating temperature: 32 to 115°F

### MARKING HEAD MODELS

- Head 50 (1.97" x 2.36")
- Head 120 (4.72" x 2.36")

### STANDARDS

- 2006/42/CE «machines» directive
- 2004/108/CE «CEM» directive
- 2006/95/CE «low voltage» directive
- FCC Chapter 15 directive

### MULTI4 CONTROL UNIT



- High resolution (640x480) color screen with icon based navigation



- Intelligent handling of the marking 
- RS232 connection, 3 Inputs / Outputs, Ethernet (optional)
- 2 USB : Device Port & HOST
- One further optional axis available (total of 4 axes)
- Embedded Multi4 software in 21 different languages
- Memory capacity of 40Mb of memory can accommodate up to 20.000 stored, marking files (40 characters, 1 line)
- Well designed ergonomics (locating foot and carriage handle)
- Fast updates in less than 2 minutes through USB port
- Various marking modes: Text, variable data, serial number, data codes, logos and 2D codes
- Straight, angular, circular and radial marking
- « Easy Shift » feature: allows to display text moving in the marking window
- (L x W x H) : 14.57" x 8.46" x 5.47"
- 8.16 lbs (including power cord)

### MAIN ACCESSORIES AND OPTIONS

- |                                |                               |                                |
|--------------------------------|-------------------------------|--------------------------------|
| 01 - Nameplate/tag support     | 06 - Extended bench           | 12 - Protection cover          |
| 02 - Parts support             | 07 - Standard Rotary D axis   | 13 - 8 Inputs / Outputs card   |
| 03 - Battery kit               | 08 - Heavy Duty Rotary D axis | 14 - Cycle start pedal         |
| 04 - Ethernet port             | 09 - Maintenance kit          | 15 - Push button box           |
| 05 - Extended column (+ 3.94") | 10 - 5 and 10 m cable         | 16 - Additional holding handle |
|                                | 11 - Software pack            |                                |



Displayed model: Multi4 50

# MULTI4<sup>®</sup> Integrated

## Compact, fits perfectly into automated processes

### ADAPTABLE

With its small footprint, integration into automated production lines is simple and easy.

### EASY TO CONFIGURATE

The Multi4 can be controlled from an external source through the serial port, robot or Ethernet connection.

### PRODUCTIVE

Possible to mark several characters per second.

### SMART

Real-time Multi4 monitoring for analysis of maintenance needs, stylus wear and detection faults (auto-diagnosis feature with 5 control points).

## APPLICATIONS

(1) Standard OCR-A marking on steel

(2) Marking of a Q.R code



1

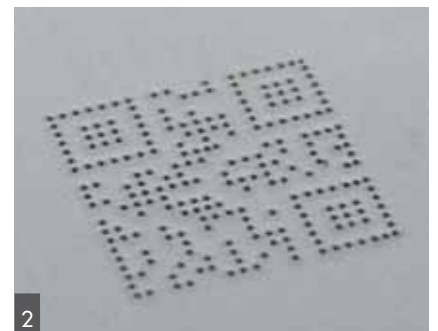

2



## TECHNICAL FEATURES (MULTI4 50)

- Marking window: 1.97" x 2.36"
- Carbide tungsten stylus with 90 degrees included angle (available in 60 and 120 degrees)

|        | Head     |
|--------|----------|
| L      | 5.71"    |
| I      | 5.67"    |
| H      | 8.90"    |
| Weight | 6.61 lbs |

Dimensions given in inches and weight given excluding the cable

## POWER AND ENVIRONMENT

- Power : 250 W
- Frequency : 50 to 60 Hz
- Input power : 90 to 240 VAC
- Operating temperature: 32 to 115°F

## MARKING HEAD MODELS



- Head 50 (1.97" x 2.36")
- Head 120 (4.72" x 2.36")
- Head 200 (7.87" x 2.36")
- Head 200 XL (7.87" x 7.87")

## STANDARDS

- 2006/42/CE «machines» directive
- 2004/108/CE «CEM» directive
- 2006/95/CE «low voltage» directive
- FCC Chapter 15 directive

## MULTI4 CONTROL UNIT



- High resolution (640x480) color screen with icon based navigation 
- Intelligent handling of the marking 
- RS232 connection, 3 Inputs / Outputs, Ethernet (optional)
- 2 USB : Device Port & HOST
- Optional 4<sup>th</sup> axis is available
- Embedded Multi4 software in 21 different languages
- Memory capacity of 40Mb of memory can accommodate up to 20.000 stored, marking files (40 characters, 1 line)
- Maintenance menu : interventions preventive management, self-diagnostic function, dashboard use
- Fast updates in less than 2 minutes through USB port
- Various marking modes: Text, variable data, serial number, data codes, logos and 2D codes
- Straight, angular, circular and radial marking
- « Easy Shift » feature: allows to display text moving in the marking window
- (L x W x H) : 14.57" x 8.46" x 5.47"
- 8.16 lbs (including power cord)

## ACCESSORIES AND OPTIONS

- |                           |                              |
|---------------------------|------------------------------|
| 01 - Ethernet port        | 05 - Software pack           |
| 02 - Maintenance kit      | 06 - Protection cover        |
| 03 - 5 and 10 m cable     | 07 - 8 Inputs / Outputs card |
| 04 - 90° cable connection |                              |

## CUSTOMISATION

With experienced Engineering and R&D departments, Technomark can develop specific solutions to meet your Direct Part Marking requirements. We do also propose complete traceability solutions.

In our R&D department, our development team is working in two areas of expertise:

- Custom engineered integration and automation for direct part marking.
- Software adaptation based upon your marking requirements.

(1) Custom engineered solution developed for industrial valves

(2) MEDK® solution developed for marking and tracking surgical instruments

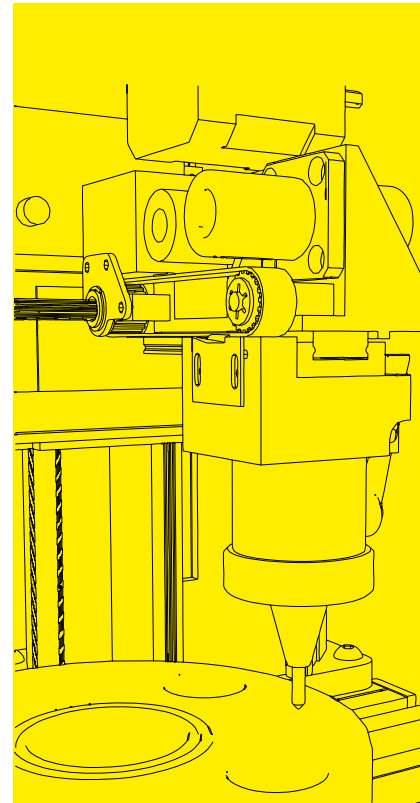

## READING

TECHNOMARK offers a complete range of the latest reading technology for 1D barcodes, 2D codes including DataMatrix and Q.R codes and standard OCR and OCR-A fonts.

Those reading systems exist both in Hand-held or Fixed version.

Datamatrix code reading



## SOFTWARE

Technomark offers a set of software dedicated to:

- Create logos with TECHNOLOG
- Production follow-up with TECHNOPROD
- Datamatrix (2D) encoding with TECHNOMATRIX
- Files transferring and backuping with TECHNOSAVE
- PC based Windows software with TECHNOWINDOWS

## MAIN ACCESSORIES AND OPTIONS



Heavy Duty Rotary D axis



Standard Rotary D axis



Automatic plate/tag feeder



Maintenance kit



Z motorized column (3<sup>rd</sup> axis) for automatic part detection



Bar end tool



Plates support

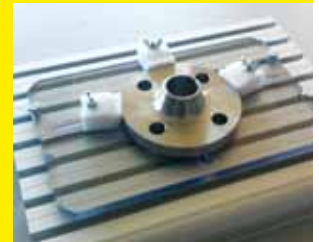

Parts support

 **TECHNOMARK**<sup>®</sup>  
CREATIVE TRACEABILITY

**MULTI 4**<sup>®</sup>  
DOT PEEN & SCRIBING



## DAPRA services

### Pre Sales

- Feasibility study
- Samples making
- On site free of charge tests

### After Sales

- Phone support
- Service
- Factory maintenance contract
- Factory or on site maintenance contract
- Product trainings to match with your needs
- Loan of material

## TECHNOMARK global presence

Our network is settled in 45 countries



**DAPRA**<sup>®</sup>  
MARKING SYSTEMS

66 Granby Street,  
BLOOMFIELD CT 06002 - USA

Tel. : 860 286 8728

Fax : 860 242-3017

E-mail : [sales@dapramarking.com](mailto:sales@dapramarking.com)

[www.dapramarking.com](http://www.dapramarking.com)