

PryorMark HD2 Portadot Series II **HAPRA** MARKING SYSTEMS

The HD2 Portadot is the best solution for permanent, direct part marking on pipe, couplings, tubing, casing, fabrications and other large components. It is ideal for deep marking requirements.



It is the better way to mark.

STANDARD FEATURES:

- Rigid head construction for industrial marking applications
- Lead screw drive for best accuracy
- Self-contained system that does not require a PC
- Operates using 115VAC, 60 Hz, NO AIR REQUIRED for standard operation
- Highly readable LCD screen (4.75" x 3.50" viewing area)
- Standard AT keyboard
- Internal layout storage (1350 maximum)
- Head-mounted start/stop switches
- Import HPGL files (.plt)
- Flat locator plate with nonskid surface
- Regrindable carbide stylus with low-stress geometries
- 15-foot cable to connect marking head to controller
- RS-232 ports for back-up, barcode input and external communications
- Digital I/O for setting inputs and outputs to external equipment
- Automatic part counters
- Automatic serialization
- Multi-level password protection
- Automatic date/time/shift coding
- Internal logo generator to create logos and symbols
- Trial run function to scan marking areas for correct location, without marking



Deep marking

SPECIFICATIONS

- Marking area: 4" x 3"
- Character sizes: .007" to 3.0" in .007" increments
- X/Y-axis resolution: .001"
- Maximum lines per layout: 40
- Character fonts: 5x7 and 7x9 dot matrix, 5x9 SEMI-OCR and Varidot (continuous line)
- Power: 115VAC, 60 Hz
- Languages: multiple
- Meets ED Directive 98/37/EC
- Meets EMC Directive 89/336/EEC
- Meets Low Voltage Directive 72/23/EEC

Net Weight:

Marking Head	25 lbs.
Controller	23 lbs.
Cable	6 lbs.

OPTIONAL HARDWARE AND ACCESSORIES

- V locator plates for marking on round surfaces
- Custom-engineered part locators and integration systems
- Surge protector
- Industrial carts to transport marking system
- Heavy-duty electric (HDE) deep marking attachment
- Pneumatic deep marking attachment



HD2 with V locator for round parts



Custom universal marking table

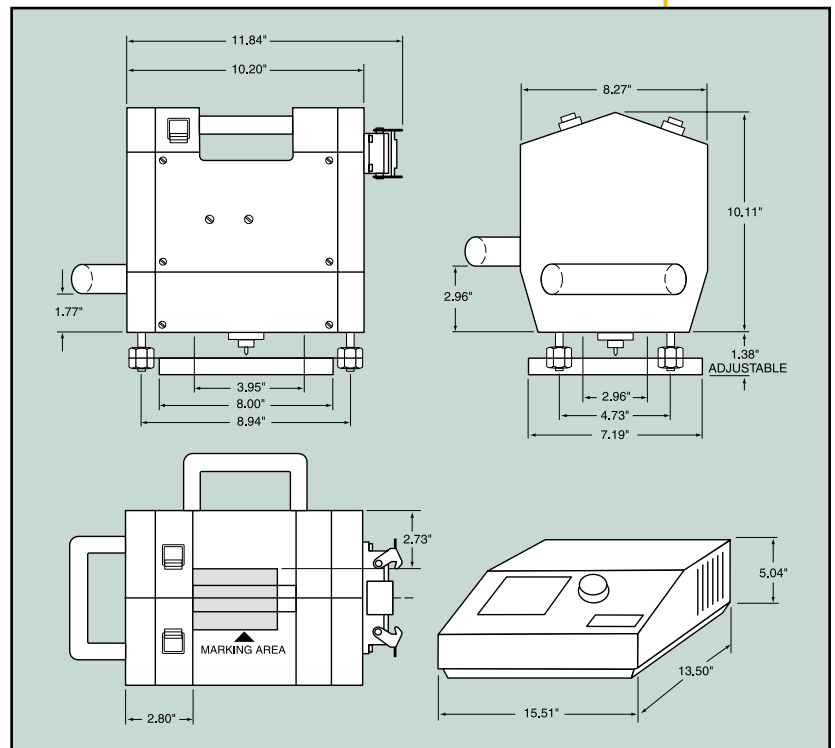

DAPRA[™]
MARKING SYSTEMS

www.dapramarking.com

Email: sales@dapramarking.com

66 Granby Street, Bloomfield, CT 06002

Tel: 800-442-6275

In CT: 860-286-8728

Fax: 860-726-9555